

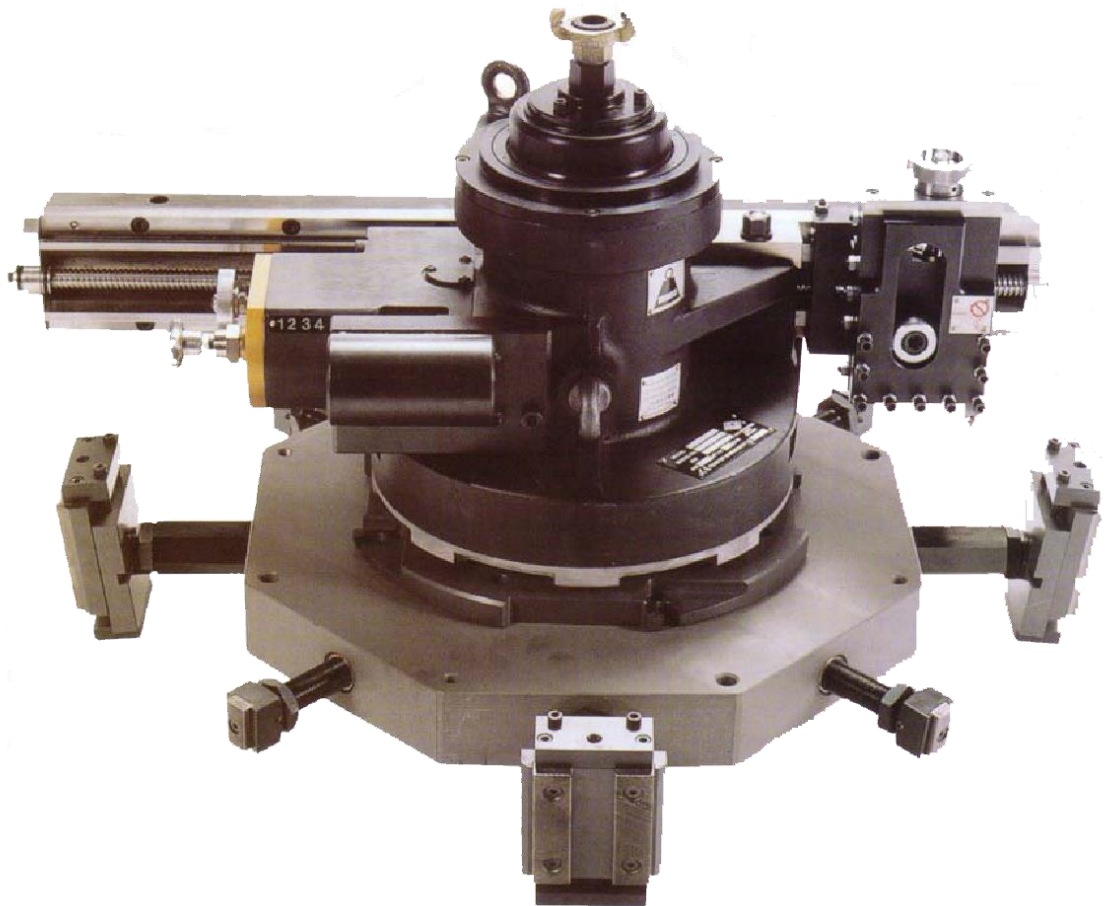

MTF1445 Flange Facing Machine

Lightweight, portable, flange facing, grooving and weld preparation machine designed to machine full faced, raised face and grooved flanges from 355mm-1140mm (14"-45")



Features

- Lightweight
- Quiet operation
- Machine shop accuracy
- Operates in any position
- Full toolkit and operators manual
- Pneumatic drive
- Fitted transportable case
- With kits supplied, will cut "V" grooves, lense ring seats and other profiles



Mactech
(EUROPE) LIMITED

UK HEAD OFFICE
EATON BANK TRADING ESTATE
RIVERDANE ROAD
CONGLETON
CHESHIRE
CW12 1PN



Mactech
(EUROPE) LIMITED

www.mactech europe.co.uk - info@mactech europe.co.uk

DECOMMISSIONING / IN-SITU MACHINING SERVICES / MACHINE SALE & RENTAL

+ 44 (0) 1260 253846

ABERDEEN OFFICE
MACTECH HOUSE
HOWE MOSS DRIVE
DYCE
ABERDEEN
AB21 0GL

+ 44 (0) 1224 722666



Mactech Europe

MTF1445 Flange Facing Machine

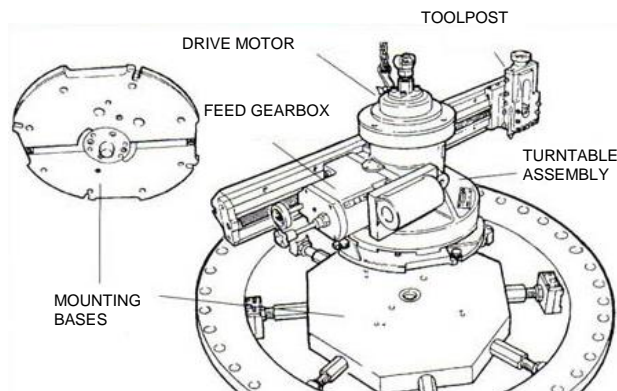

Typical Applications

- Lens Ring Seat Cutting and
- Polishing 'V' Groove Cutting
- Tube Sheet Machining

Mactech MTF1445 is constructed, as is the rest of the range, from the highest quality materials. It is designed to give machine shop accuracy, combined with ease of handling and portability, in the flange range of 355mm (14") to 1140mm (45"). The machine consists of four main assemblies:

Base

The mounting bases for the machine are supplied in two sizes to ensure maximum stability throughout the machining range. The bases are set up using the clocking tower bar supplied, to centralise and level the base exactly. A base is adjusted parallel to the flange by four micro precision pads. It has a detachable locating spigot fitting into a hardened bush, ensuring the machine is positioned as accurately as the base is set.

Drive Hub

A 2.61kw (3.5hp) air motor is contained within the drive hub, giving plenty of power to tackle welds, bolt holes and more exotic materials such as stainless steels. The machine is surprisingly quiet, as the exhaust is vented down the bore and muffled by its body.

Drive Gearbox

The versatility of this machine is a direct result of the use of the Silk 4-speed gearbox. This allows the machine to feed in or out to give a continuous spiral finish.

Adjustable Arm and Toolpost

Sliding in a dovetail clamp enables the surfacing arm to be positioned to suit the flange, or any obstructions around it. The arm is clamped on the dovetail and pressed down onto hardened pads to maintain accuracy. The swivel toolpost can be tilted for weld preparation, grooving or special applications.

Specifications

Principal dimensions

Machine height	410mm (16½")
Mounting base thickness	63.5mm (2½")
Maximum rotational diameter	1150mm (45¼")
Minimum rotational diameter	800mm (31½")
Toolpost travel	40mm (1⅞")

Weights

Machine weight (less base)	105kg (231½lbs)
Nett weight (less wooden case)	227kg (500lbs)
Total shipping weight	30kg (660lbs)

Transportable case dimensions

Length	1015mm (40")
Height	810mm (32")
Width	640mm 25"

General information

Depth of flange required to set base	130mm (5⅛")
Machine height above flange face	345mm (13¾")
Final rotational speed	30rpm

Gripping range:

Minimum recommended bore	355mm (14")
Maximum recommended bore	965mm (38")

Facing range:

Minimum diameter	355mm (14")
Maximum diameter	1143mm (45")

Drive motor:

Minimum air supply requirements	2.61kw (3.5hp) 6 bar 2.69m ³ /min (90psi 95cfm)
---------------------------------	--

Drive motor output speed

185rpm

Internally Mounted Flange Facing Machines

UK HEAD OFFICE
EATON BANK TRADING ESTATE
RIVERDANE ROAD
CONGLETON
CHESHIRE
CW12 1PN



Mactech
(EUROPE) LIMITED

www.mactech europe.co.uk - info@mactech europe.co.uk

DECOMMISSIONING / IN-SITU MACHINING SERVICES / MACHINE SALE & RENTAL

ABERDEEN OFFICE
MACTECH HOUSE
HOWE MOSS DRIVE
DYCE
ABERDEEN
AB21 0GL



Mactech
(EUROPE) LIMITED

+ 44 (0) 1260 253846

+ 44 (0) 1224 722666