



Diamond Wire Saws



**Mactech**  
(EUROPE) LIMITED

## Why Choose Mactech Offshore?

- Mactech makes a total and commitment to safe working practices, both in equipment design and services performed
- Focus on producing the best cut times in the offshore industry
- Emphasis on reliability and consistency in DWS design to produce full thru-cuts on pipe section, giving operators confidence and confirmation in cuts
- Tools, procedures and problem-solving techniques incorporate hands-on technician input and experience
- Best practices approach under continual scrutiny and revision
- OEM in-house product development breeds innovation
- Providing solutions for complicated technical problems
- Broad and deep range of offshore equipment and assets on-site
- “A” safety rating on ISN
- Made in the USA



Mactech Offshore offers a wide selection of Diamond Wire Saws for Subsea and Topside cutting of a variety of materials and in challenging environments. Diamond Wire Saws are ideal for cutting multi-string casing or heavy wall legs and cross members.

### Applications include:

- Offshore decommissioning
- Subsea cutting
- Topside cutting
- Bridge piling removal
- Well head removal
- Large diameter severing
- Slot recovery
- Marine construction

The compact and robust design creates an ideal cutting environment, reducing setup, installation, and removal time – saving you time and money.

Mactech Diamond Wire Saws are easily customizable and adaptable to specific project needs. Our versatile range includes the ultra-compact and lightweight DWS-16co, to the large diameter capacity DWS-102i. The unique DWS-40a and DWS-60a Articulating Diamond Wire Saws are designed for below-the-mudline or low clearance cuts. The ROV models are capable of subsea, deepwater cutting. All of Mactech's Diamond Wire Saws are designed to give you maximum cutting range flexibility, the smallest footprint and the reliability you expect from Mactech products.

The workhorse of the diamond wire saw fleet, our Inline Saws have all the features you need to efficiently cut casing and structures. These saws have performed thousands of successful cuts in the Gulf of Mexico and around the world.

- Used for subsea and topside cutting
- Operates in any position
- Cuts multi-string casing, square piles, steel and concrete
- Easily modified for specialized cuts
- Cuts in any orientation, upside-down, right-side up, or at any angle



DWS-26i Inline Saw	
Cutting Capacity	8 to 26 inches 2184 to 1549 mm
Operating Dimensions	86 x 61 x 40 inches 2184 x 1549 x 1016 mm
Shipping Dimensions	86 x 61 x 43 inches 2184 x 1549 x 1092 mm
Operating Weight	1025 lbs. 465 kg
Shipping Weight	1325 lbs. 601 kg



DWS-30i Inline Saw	
Cutting Capacity	16 to 30 inches 406 to 762 mm
Operating Dimensions	86 x 65 x 40 inches 2184 x 1651 x 1016 mm
Shipping Dimensions	86 x 65 x 43 inches 2184 x 1651 x 1092 mm
Operating Weight	1050 lbs. 476 kg
Shipping Weight	1350 lbs. 612 kg

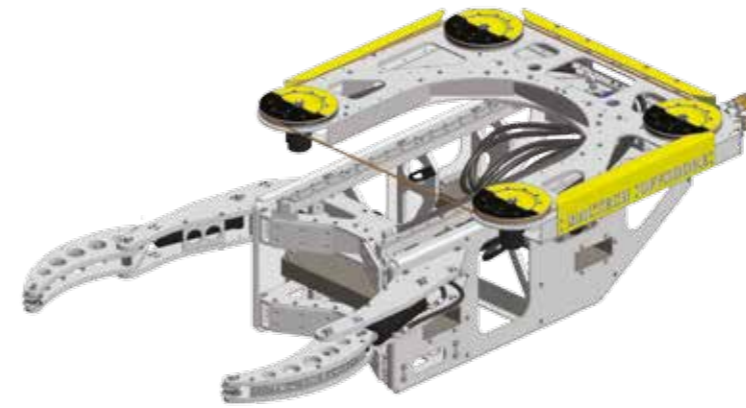

DWS-40i Inline Saw	
Cutting Capacity	20 to 40 inches 508 to 1016 mm
Operating Dimensions	133 x 74 x 38 inches 3378 x 1880 x 965 mm
Shipping Dimensions	109 x 74 x 38 inches 2769 x 1880 x 965 mm
Operating Weight	1650 lbs. 748 kg
Shipping Weight	1650 lbs. 748 kg



DWS-48i Inline Saw	
Cutting Capacity	20 to 48 inches 508 to 1219 mm
Operating Dimensions	134 x 82 x 38 inches 3404 x 2083 x 965 mm
Shipping Dimensions	115 x 82 x 38 inches 2921 x 2083 x 965 mm
Operating Weight	1680 lbs. 762 kg
Shipping Weight	1680 lbs. 762 kg

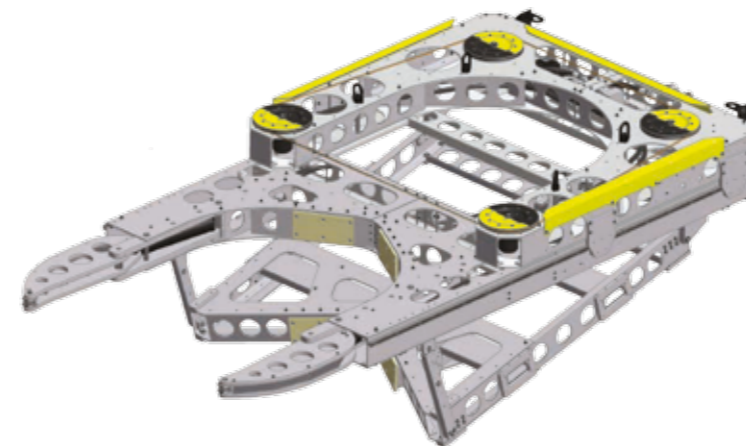

DWS-60i Inline Saw	
Cutting Capacity	26 to 60 inches 660 to 1524 mm
Operating Dimensions	165 x 98 x 55 inches 4191 x 2489 x 1397 mm
Shipping Dimensions	145 x 98 x 33 inches 3683 x 2489 x 838 mm
Operating Weight	2575 lbs. 1168 kg
Shipping Weight	2575 lbs. 1168 kg



DWS-102i Inline Saw	
Cutting Capacity	48 to 102 inches 1219 x 2591 mm
Operating Dimensions	165 x 138 x 69 inches 4191 x 3505 x 1753 mm
Shipping Dimensions	165 x 60 x 73 inches 4191 x 1524 x 1854 mm
Operating Weight	2375 lbs. 1077 kg
Shipping Weight	2450 lbs. 1111 kg



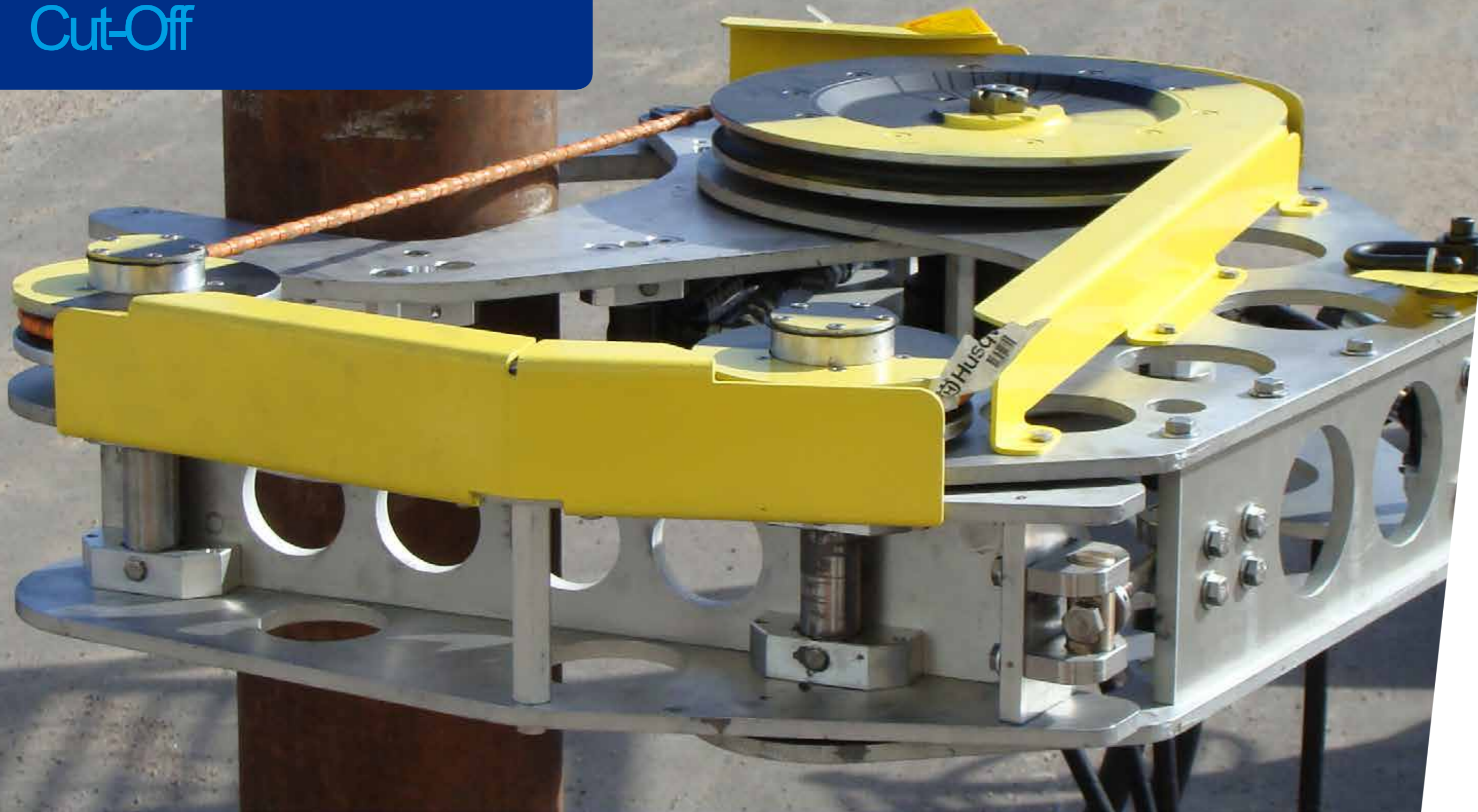

Compact and portable, our Cut-off saws work in areas where larger saws can't reach, or where manoeuvrability and ease of positioning is required. The Cut-off Saw is light and small, making it easy for divers to set up. Get all the capabilities of our larger saws in an affordable and easy to use unit.

- Cuts pipe, multi-string casing and pilings, even cuts bundled wire
- Lightweight and easy to maneuver. The DWS-16co weighs only 210 lbs.
- Cuts round or square structures
- Robust design allows for continued operation in tough conditions

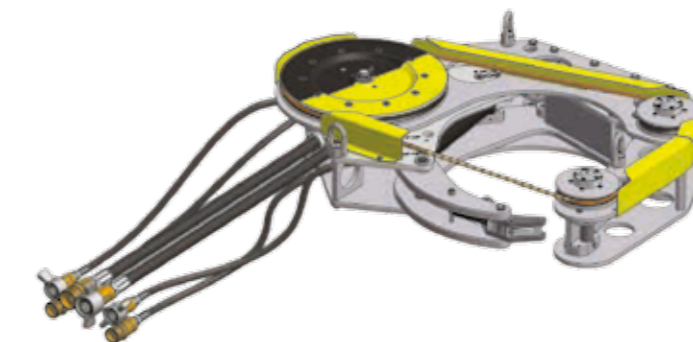

### DWS-16co Cut-off Saw

Cutting Capacity	4 to 16 inches (102 to 406 mm)
Operating Dimensions	43 x 24 x 10 inches 1092 x 610 x 254 mm
Shipping Dimensions	60 x 48 x 36 inches 1524 x 1219 x 914 mm
Operating Weight	210 lbs. 95 kg
Shipping Weight	650 lbs. 295 kg

### DWS-24co Cut-off Saw

Cutting Capacity	16 to 24 inches round 10 to 20 inches square 406 to 610 mm round 254 to 508 mm square
Operating Dimensions	39 x 48 x 19 inches 991 x 1219 x 483 mm
Shipping Dimensions	68 x 51 x 38 inches 1727 x 1295 x 965 mm
Operating Weight	320 lbs. 145 kg
Shipping Weight	950 lbs. 431 kg



# Articulating

The patented design of our Articulating Diamond Wire Saws increase the efficiency and effectiveness of low-clearance cuts in the subsea cutting world. The articulated design only requires 2 feet of clearance around casings and the cut is made at the bottom of the saw, so there is no need to make additional space and can minimize dredge requirements.

- US Patents 8,651,098B2, 8,833,359,B2, 9,010,311B1
- Cuts flat with mudline at bottom of the saw
- Reduces backside clearance footprint up to 70%, compared to inline DWS
- Reduces equipment footprint up to 55% compared to inline DWS
- Reduces excavation footprint allowing up to 94% reduction of material to be dredged
- Ideal for cutting multi-string applications or heavy wall legs
- Designed to reduce setup, installation and cut times
- All Mactech Diamond Wire Saws can be customized for ROV capability

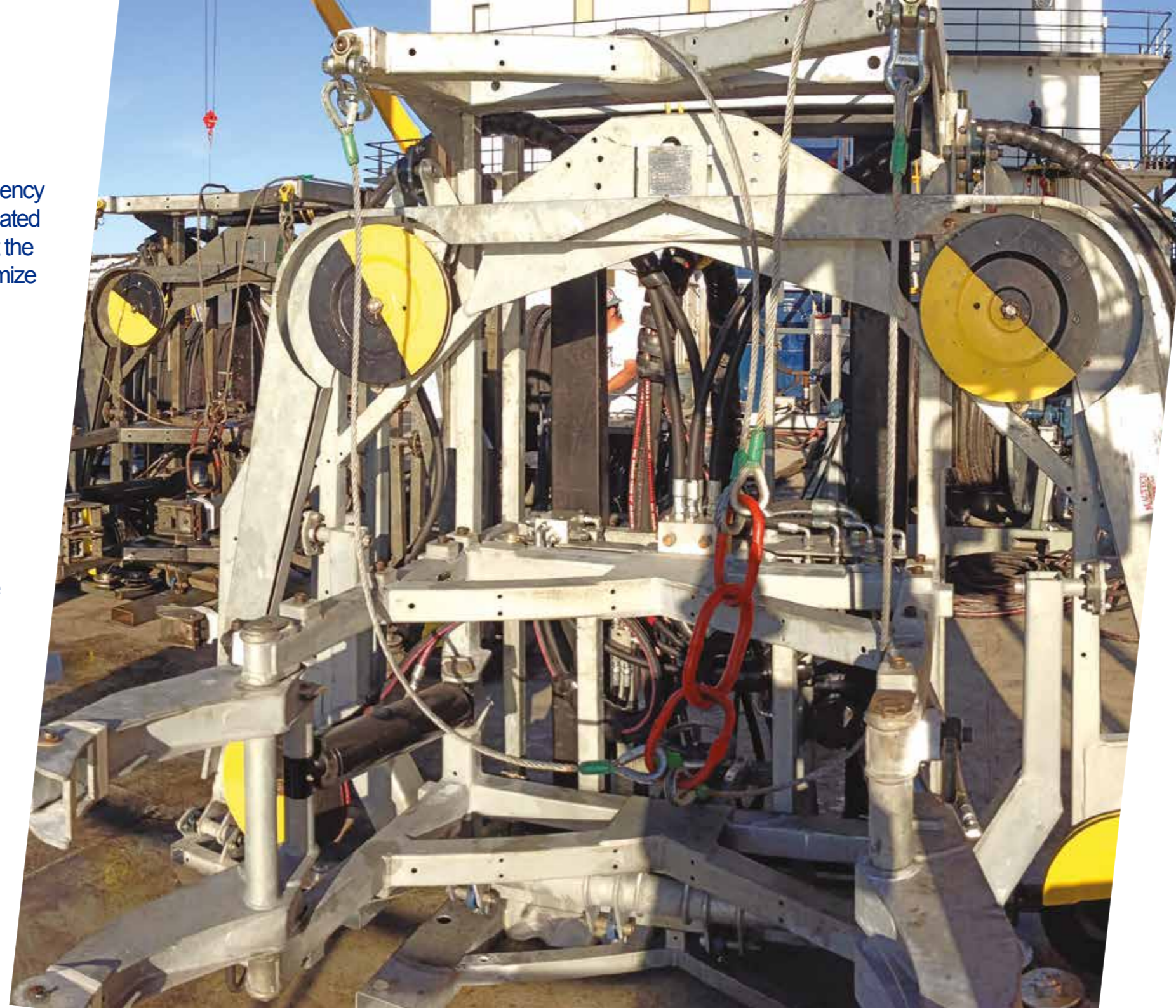

## DWS-40a Articulating Saw

Cutting Capacity	22 to 40 inches 559 to 1016 mm
Operating Dimensions	60 x 107 x 86 inches 1524 x 2718 x 2184 mm
Shipping Dimensions	60 x 107 x 86 inches 1524 x 2718 x 2184 mm
Operating Weight	2400 lbs. 1089 kg
Shipping Weight	2550 lbs. 1157 kg

## DWS-60a Articulating Saw

Cutting Capacity	26 to 60 inches 660 to 1524 mm
Operating Dimensions	102 x 109 x 128 inches 2591 x 2769 x 3251 mm
Shipping Dimensions	98 x 109 x 97 inches 2489 x 2769 x 2464 mm
Operating Weight	3200 lbs. 1451 kg
Shipping Weight	3200 lbs. 1451 kg



# Patented Articulating Design

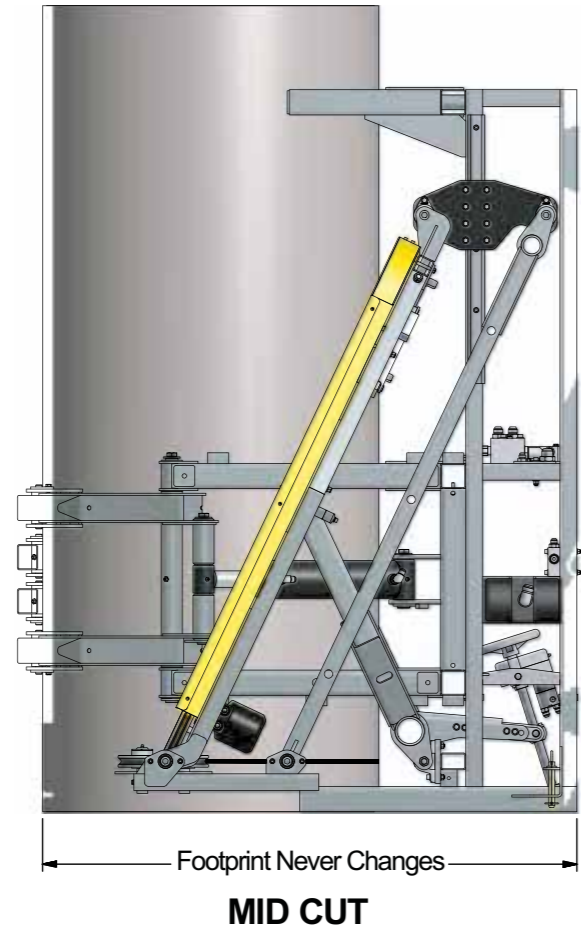
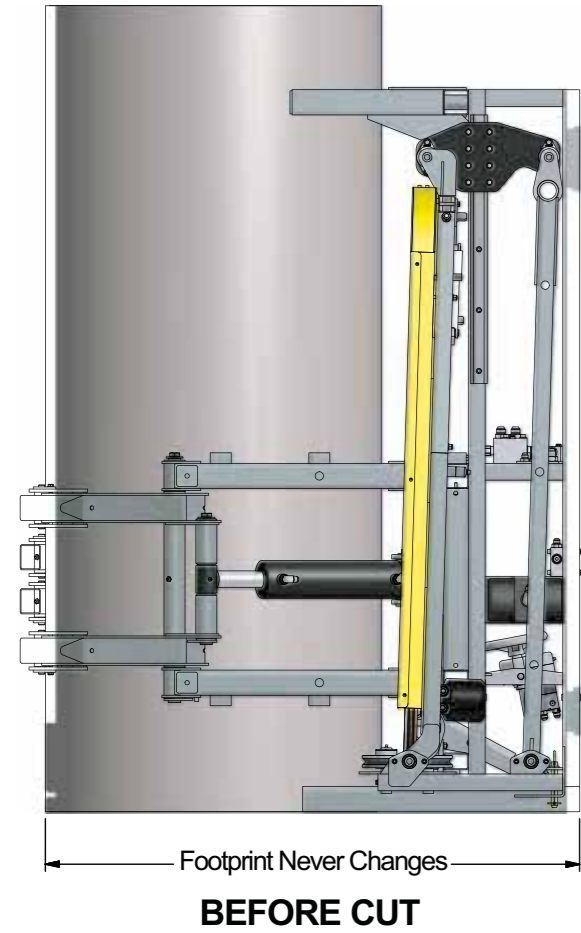

Articulating Saws cut perpendicular to the pipe axis

## Less Excavation Required

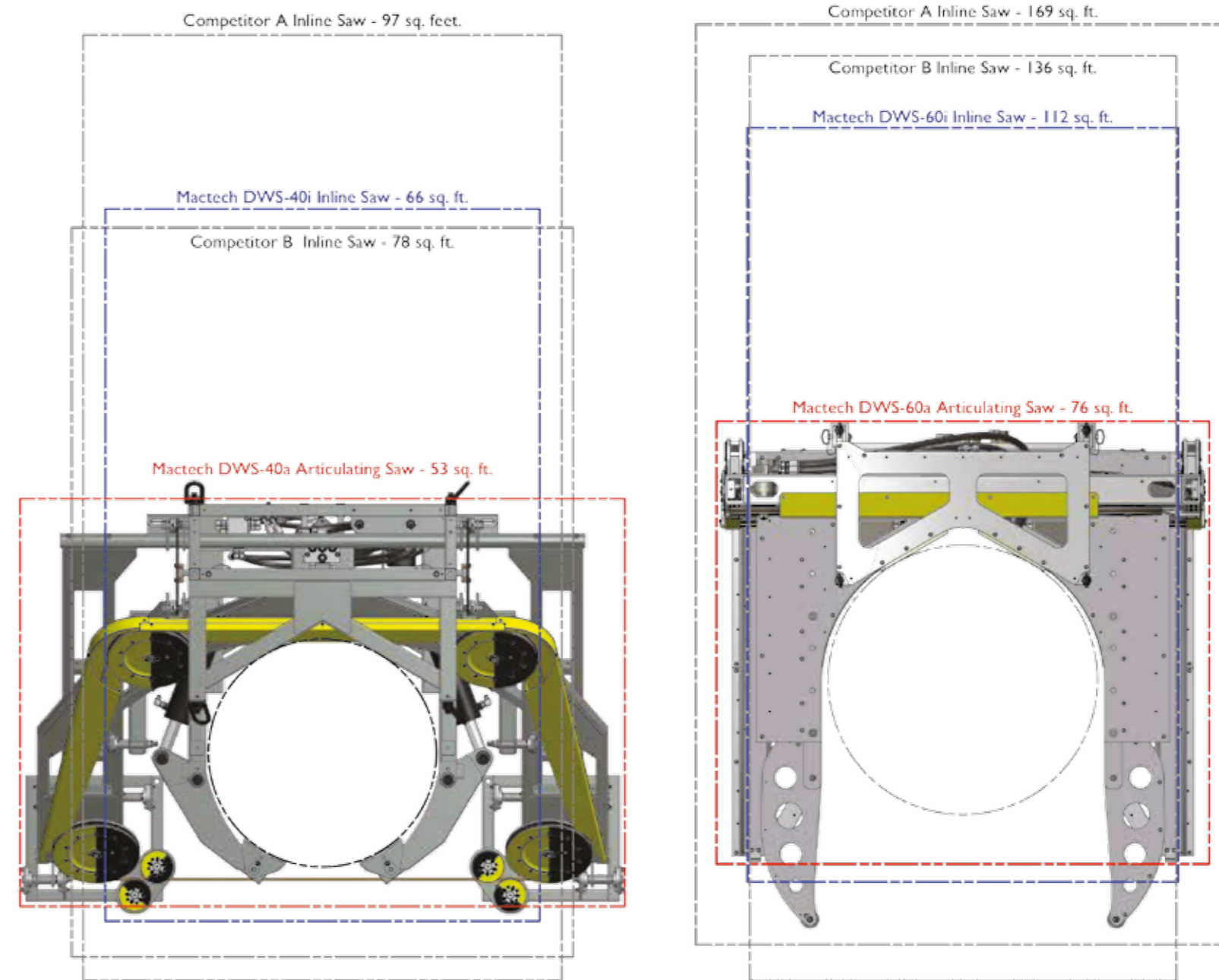

Reduces backside clearance footprint up to 70%

Reduces equipment footprint up to 55%

# Articulating

## DWS-40a Articulating / DWS-40i Inline Dredging Requirements

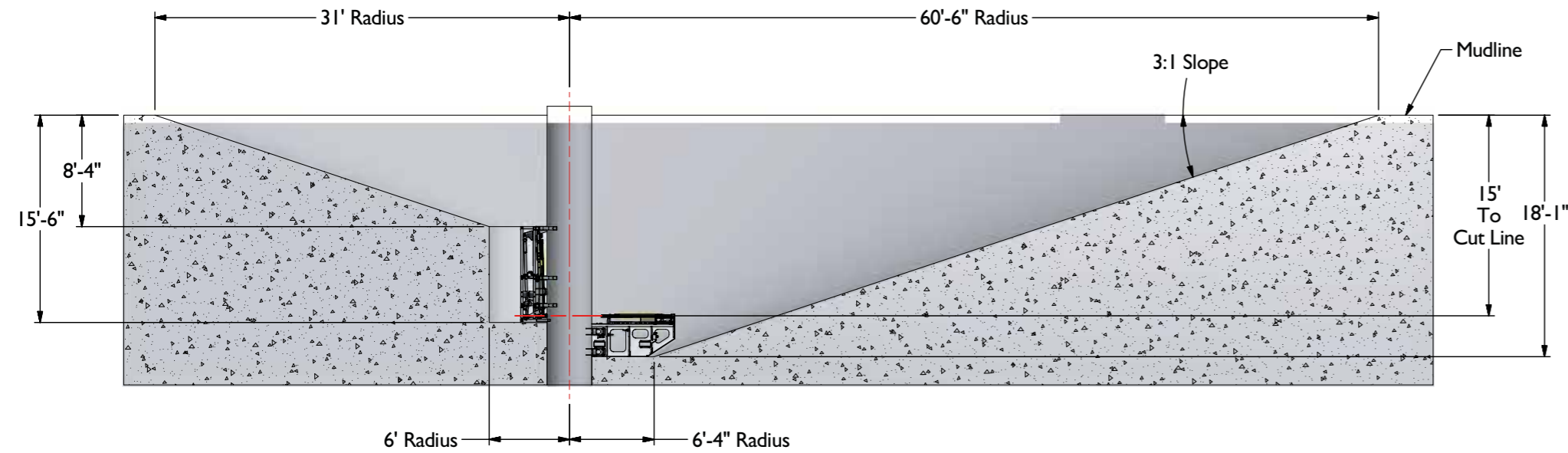

**DWS-40a Articulating Saw**  
~410 cubic yards dredge for a  
15 ft. below the mudline cut.

**DWS-40i Inline Saw**  
~2900 cubic yards dredge for a  
15 ft. below the mudline cut.

**Up to 86% reduction of material to be removed**

## DWS-60a Articulating / DWS-60i Inline Dredging Requirements

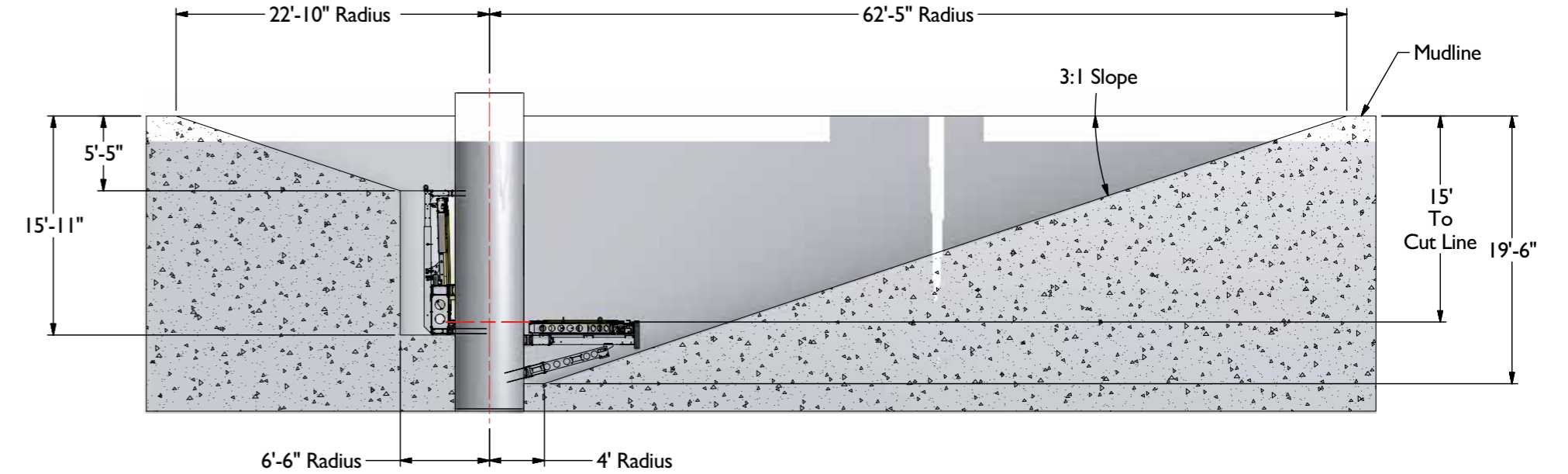

**DWS-60a Articulating Saw**  
~200 cubic yards dredge for a  
15 ft. below the mudline cut.

**DWS-60i Inline Saw**  
~3200 cubic yards dredge for a  
15 ft. below the mudline cut.

**Up to 94% reduction of material to be removed**

# ROV

The ROV Diamond Wire Saw is designed to address economical efficiencies and advantages while focusing on personnel and environmental safety while performing abandonment operations.

Mactech's ROV Diamond Wire Saw offers operators and contractors the ability to keep divers out of the water, maintain controllable and precise cuts, and operate at a subsea weight of approximately 160 lbs.

- 150 lbs. subsea weight
- Depth rates to 3000 m
- Integrated compensation system with hot stab connections
- Capable of ROV-Powered or Surface-Powered with ROV positioning

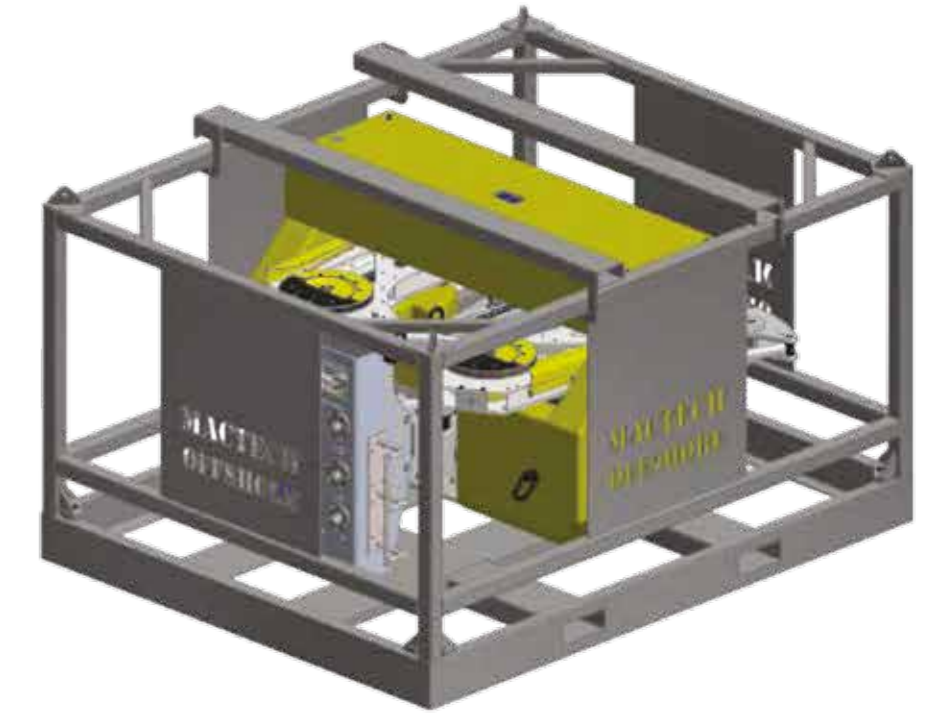
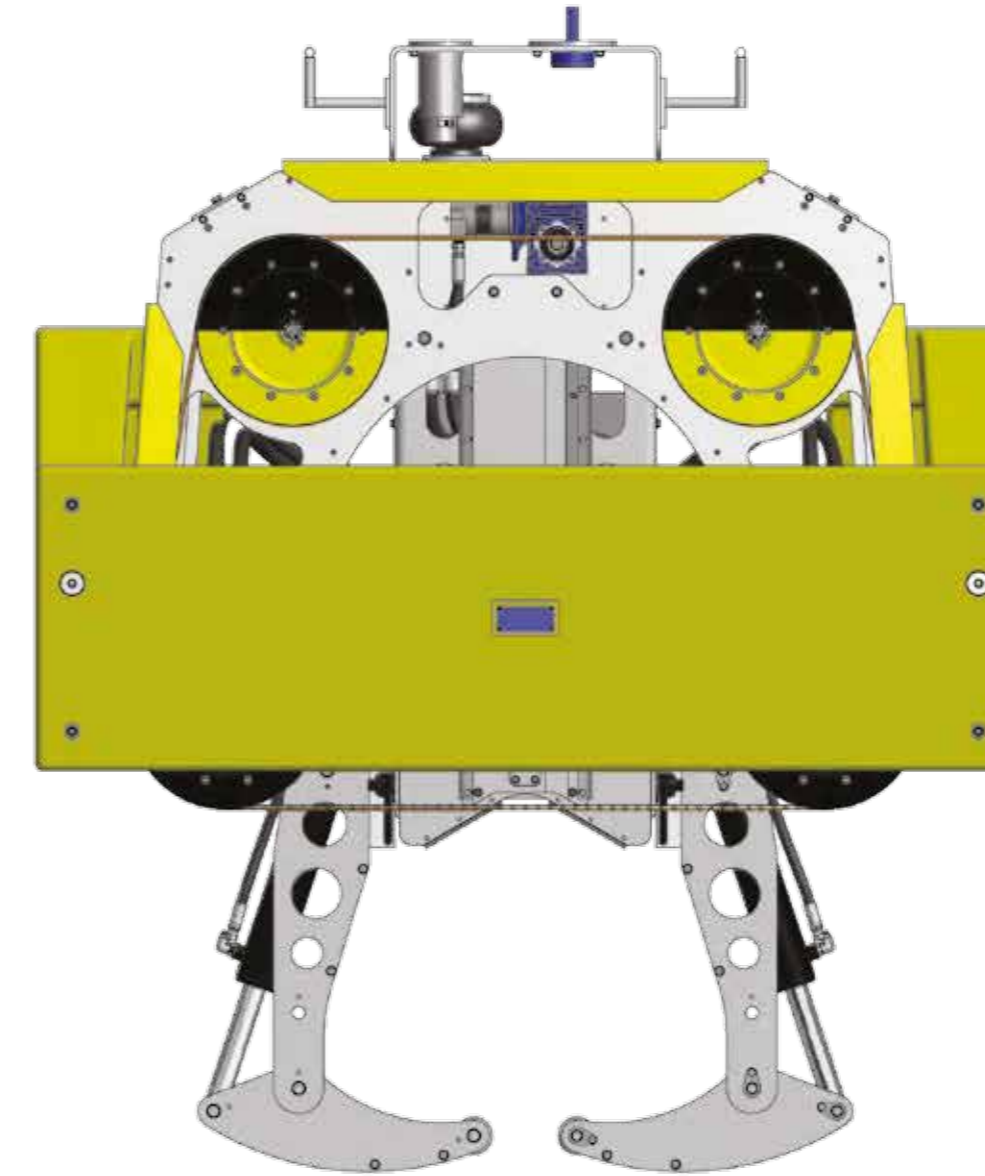
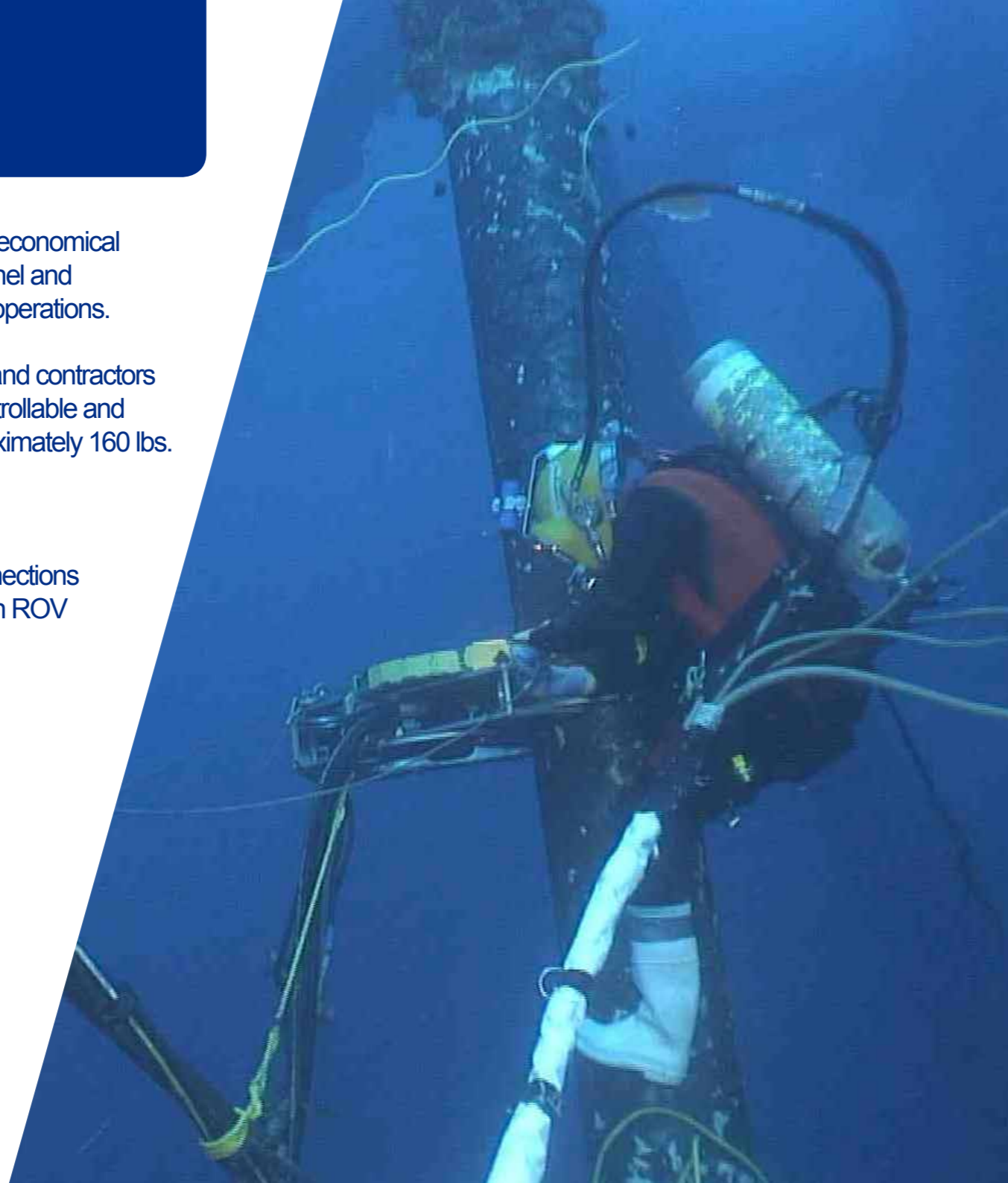

## DWS-30I ROV Saw

Cutting Capacity	10 to 30 inches 254 to 762 mm
Operating Dimensions	93 x 78 x 51 inches 2362 x 1981 x 1295 mm
Shipping Dimensions	110 x 88 x 65 inches 2794 x 2235 x 1651 mm
Operating Weight	2700 lbs. 1225 kg
Shipping Weight	4800 lbs. 2177 kg





**Mactech**  
(EUROPE) LIMITED



[www.mactechurope.co.uk](http://www.mactechurope.co.uk)

[info@mactechurope.co.uk](mailto:info@mactechurope.co.uk)

Head Office + 44 (0) 1260 281431

Aberdeen Office + 44 (0) 1224 722666

**Mactech Europe - Head Office**

Mactech House  
Riverdane Road  
Eaton Bank Trading Estate  
Congleton  
Cheshire  
CW12 1PN

**Mactech Europe - Aberdeen Office**

Mactech House  
Howe Moss Drive  
Kirkhill Ind. Estate  
Dyce  
Aberdeen  
AB21 0GL

**Mactech Offshore**

302 Ida Road  
Broussard  
LA 70518  
United States  
[www.mactechoffshore.com](http://www.mactechoffshore.com)  
[info@mactechoffshore.com](mailto:info@mactechoffshore.com)  
1 -337-839-2793

