



I.D. Milling Machine

From 18 inch I.D. to 27 inch O.D. (457 mm I.D. To 686 mm O.D.) O.D.

Mactech's ID Milling Machine reliably cuts casing, pilings, and other round, hollow tube from the inside of the pipe

Simply lower the ID Milling Machine into the pipe, activate the self-centering mechanism, and begin the cut.

The self-centering clamps assure accurate and secure placement. In subsea applications, cutting below the mudline requires costly and time-wasting dredging around the casing.

The ID Milling Machine eliminates the need for excavation around subsea structures, saving time and expense.

Mactech's unique ID Milling Machine is your solution to limited access, round tube severing applications.

Benefits

- Cold cut pilings, casings, or other round, hollow tube.
- Inside diameter cutting eliminates the need for subsea dredging around casings.
- Cuts 18 to 27 inch inside diameter pipe.
- Self-centering makes setup quick and easy.
- Uses standard 1 inch end mill.

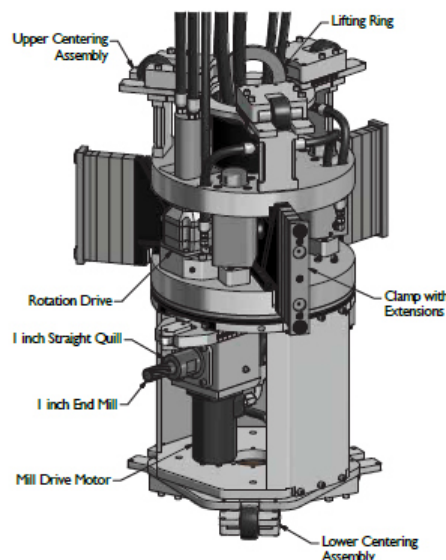



I.D. Milling Machine

From 18 inch I.D. to 27 inch O.D. (457 mm I.D. To 686 mm O.D.) O.D.

Specifications

| | |
|----------------------|--------------------------------------------------------------------------------------------------------------------------------------------|
| Tooling | 1 inch (25.4 mm) End Mill |
| HPU Requirement | 20 gpm @ 2000 psi continuous pressure. Adjustable flow and pressure control. Hydraulic power units are available from Mactech Europe |
| Control Cart | Mactech Europe recommends the use of the control cart for controlling all hydraulic functions. |
| Operating Weight | 405 lbs (184 kg) |
| Shipping Weight | 995lbs (451kg) |
| Hose Shipping Weight | 426lbs (193kg) |

Machine is shown in the operating position.set for 27 inch diameter

