



MT30 Portable Rack Drill

Versatile & Powerful Portable Drilling

MT30 Portable Rack Drill is a versatile and easy to use drill for on-site drilling.

The MT30 Rack Drill is ideally suited for applications where quick set-up and powerful drilling is required.

An optional hanger bracket allows the drill to be positioned at a set distance from the top of pipe or other structure.

An optional magnet attachment allows the MT30 Portable Rack Drill to be easily attached to almost any ferrous surface.

The MT30 Portable Rack Drill can be customised with mounting options, tool holders and motors for your applications



Features

- Powerful air, hydraulic or electric motors drill quickly through the toughest materials.
- Portable, compact and lightweight design makes drilling in hard to reach spaces easy.
- Optional magnetic attachment base mounts securely to flat or round ferrous surfaces.
- Optional hanger bracket for quick and secure placement and drilling on pipe or structure.
- Wide variety of arbors, tool holders and motors are available.

Capabilities

- Drilling
- Boring
- Tapping (Optional reversible motor required)

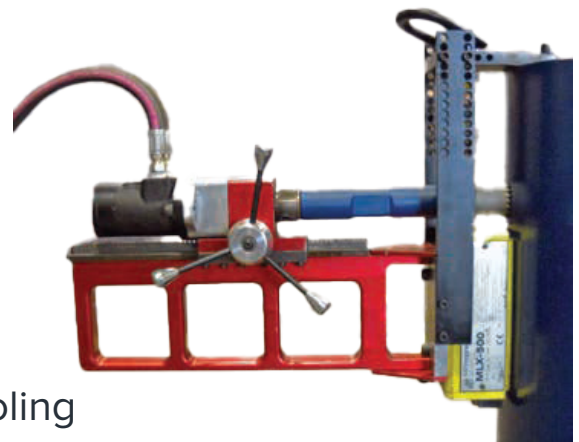

Tooling

Mactech carries a full line of drill bits for most drilling operations. Drill capacity is 1-1/2 inch twist and 3 inch annular.



MT30 Portable Rack Drill

Versatile & Powerful Portable Drilling

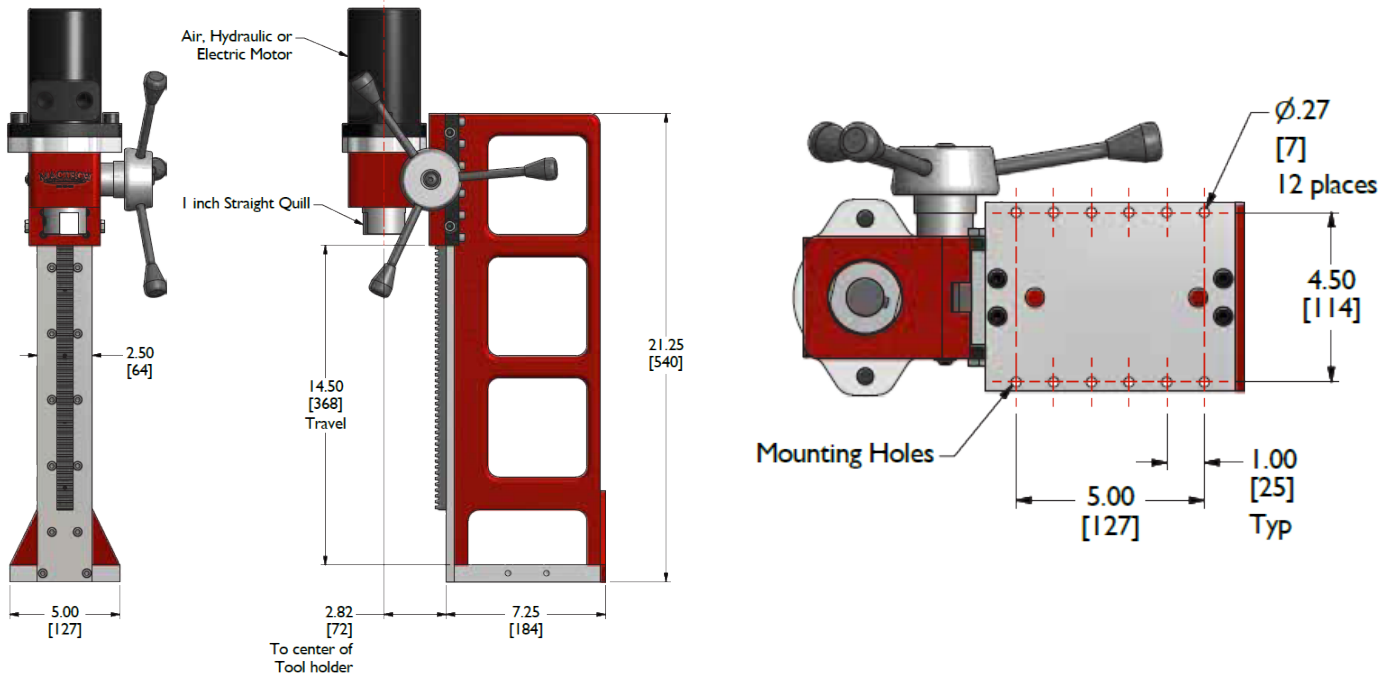

Technical Specifications

Pneumatic Motor	1.45 maximum HP, 105-220 RPM
Hydraulic Motor	2.4 HP, 20-450 RPM
Hydraulic Power	3 HP
Variable Frequency Drive Supply	0-3 gpm@ 1500 PSI
Arbor	3 MT standard Also available in 1" straight shank (female)
Drill Capacity	1½" Twist, 3" Annular

Hydraulic Motor Performance Specifications

Displacement	Torque@2- 6 gpm	Torque@6 -10 gpm	Torque@10 - 15 gpm
	RPM	RPM	RPM
9.7 in/rev	101 - 102 ft lbs	99 - 101 ft lbs	98 - 99 ft lbs
	44 - 138	138 - 232	232 - 348

Note: Performance is based on hydraulic power supply of 1000 psi continuous pressure

Air Motor Performance Specifications

Motor Option	Max Output	Torque at Max Output	Speed at Max output	Air Consumption at Max Output
A	2.41 hp	100 ft lbs	128 rpm	76.3 cfm
B	2.41 hp	164 ft lbs	77 rpm	76.3 cfm

Note: Performance is based on air supply of 91 psi continuous pressure



MT30 Portable Rack Drill

Versatile & Powerful Portable Drilling

Technical Specifications

Arbor	#3 Morse Taper
	1 inch female straight shank
Drill Capacity	1-1/2 inch twist drill
	3 inch annular
Magnetic Mounting Box	Max Load - Flat Surface: 1100 lbs (499kg)
	Max Load - Round Surface: 550 lbs (249.4kg)
	Detachment Force: 3575 lbs (1621.6kg)
Weights	Rack Drill with Hydraulic Motor: 42 lbs (19kg)
	Rack Drill with Air Motor: 45 lbs (20kg)
	Magnetic Base: 35 lbs (15.9kg)
	Hanger Bracket: 17 lbs (8kg)



3 HP, 220 volt hydraulic power supply with remote pendant.

Accessories

- Piloted Drills
- Annular Cutters
- #3 MT Spindle
- 1 inch keyed female spindle
- V-bracket
- Horizontal Hanging Bracket
- Custom Fixturing

